

Computer Organization' 2013

Tutorial # 2

September 2, 2013

1. Find out the switching expression corresponding to: $f(A, B, C, D) = \Sigma(1, 4, 5, 9, 11, 12)$.

Ans . $\bar{A}\bar{C}D + B\bar{C}\bar{D} + A\bar{B}D$

2. The literal count of a Boolean expression is the sum of the number of times each literal appears in the expressions. For example, the literal count of $(xy + xz')$ is 4. What are the minimum possible literal counts of the product-of-sum and sum-of-products expressions respectively of the functions given by the following Karnaugh-Map? X denotes the don't care.

xy \ zw	00	01	11	10
00	X	1	0	1
01	0	1	X	0
11	1	X	X	0
10	X	0	0	X

For sum of the product: (and similarly for POS)

xy \ zw	00	01	11	10
00	X	1	0	1
01	0	1	X	0
11	1	X	X	0
10	X	0	0	X

sop = $\bar{X}\bar{Y}\bar{W} + \bar{X}Y\bar{Z} + Y\bar{Z}W + X\bar{Z}\bar{W}$
 Literal count for sop = 12

3. If X is don't care, what is minimum function for the following Karnaugh-Map?

xy \ zw	00	01	11	10
00	1	1		1
01	X			
11	X			
10	1	1		X

Ans. Minimum function = $\bar{Y}\bar{Z} + \bar{Y}Z\bar{W} = \bar{Y}\bar{Z} + \bar{Y}\bar{W}$

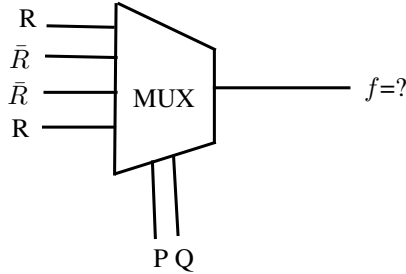
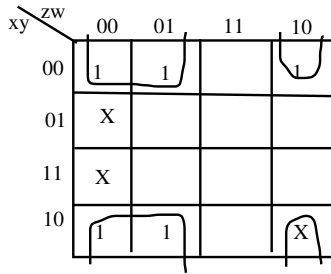

4. What is the Boolean expression for the output f for multiplexer shown below?

Ans. $f = R(\bar{P}\bar{Q} + PQ) + \bar{R}(\bar{P}Q + P\bar{Q})$

5. Simplify the following expression using Karnaugh-Maps?

$$(P + \bar{Q} + \bar{R})(P + \bar{Q}) + (P + \bar{Q} + R)(P + Q + \bar{R}).$$

Ans. In truth-table of P,Q,R, f(P,Q,R), the only of 010 is having result 0, rest all are 1. Hence, $f = (P + \bar{Q} + R)$

6. Construct the K-Map solution for 7-Segment display. The input value 0-9 (BCD) should display the corresponding hex code on the seven segment display.

Ans The display and Truth table are shown in figures 1, and table 1.

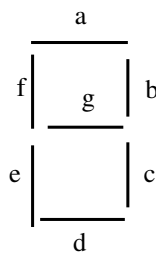

Figure 1: 7-Segment Display.

7. Consider the following circuit in figure 2 involving positive edge triggered D-FF.

Consider the following timing diagram. Let A_i represents the logic level on the line A in the i^{th} clock period.

Let A' represents the complement of A . The correct output sequence Y over the clock period 1 through 5 is:

- a) $A_0A_1A'_1A_3A_4$ b) $A_1A_2A'_2A_3A_4$
- c) $A_0A_1A_2'A_3A_4$ d) $A_1A'_2A_3A_4A_5$

Ans. Correct Answer is A. (note that the value A_i is effective in the clock period, that means - not before the start of the clock period).

Table 1: Truth table for seven segment display.

x1,x2,x3,x4	a,b,c,d,e,f,g
0000	1111110
0001	0110000
0010	1101101
0011	1111001
0100	0110011
0101	1011011
0110	1011111
0111	1110000
1000	1111111
1001	1111011
1010	1110111
1011	0011111
1100	1001110
1101	0111101
1110	1001111
1111	1000111

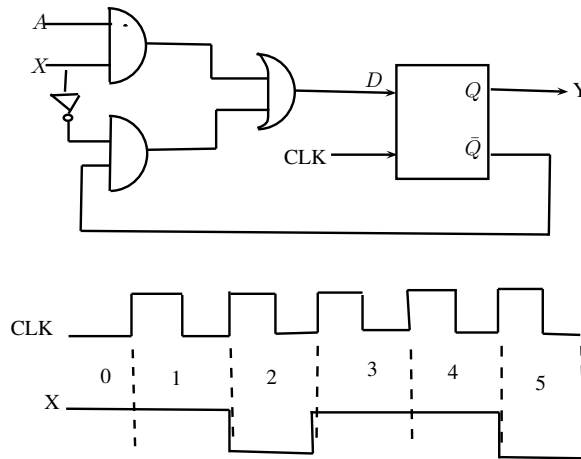

Figure 2: D-FF circuit

8. Consider the following circuit composed of XOR gates (figure 3) and non-inverting buffers.

The non-inverting buffers have delays of $\delta_1 = 2ns$ and $\delta_2 = 4ns$. Both XOR and wires have zero delays. If the above waveform's 7-cycles are applied at input A, how many transition(s) (change of levels) occur at B during the interval $0 - 7ns$?

Ans. Total change of levels=6

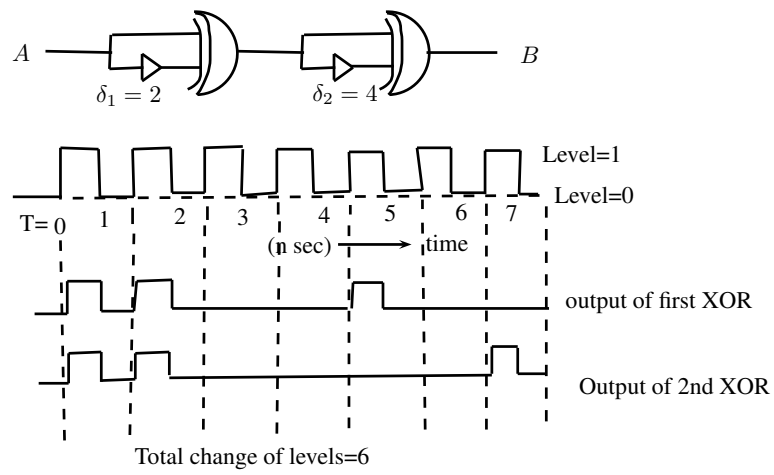

Figure 3: XOR Circuit and waveform.